

EROWA®
system solutions

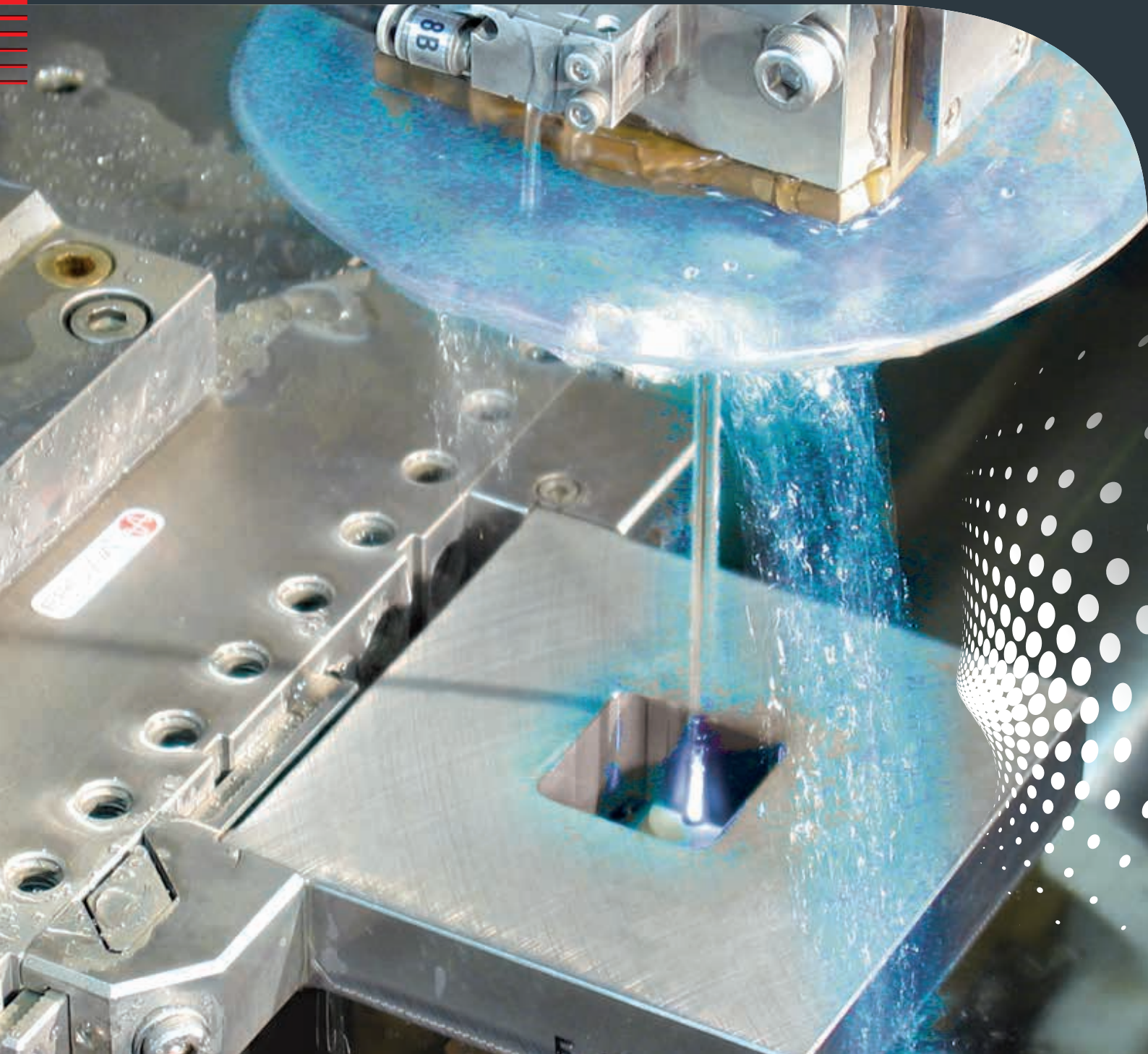

Wire EDM Tooling

The tooling system for WEDM



The right choice

The expandable EROWA Wire EDM tooling system.
It grows with your needs.

“We gain 660 productive hours per year.
This makes us very competitive!”

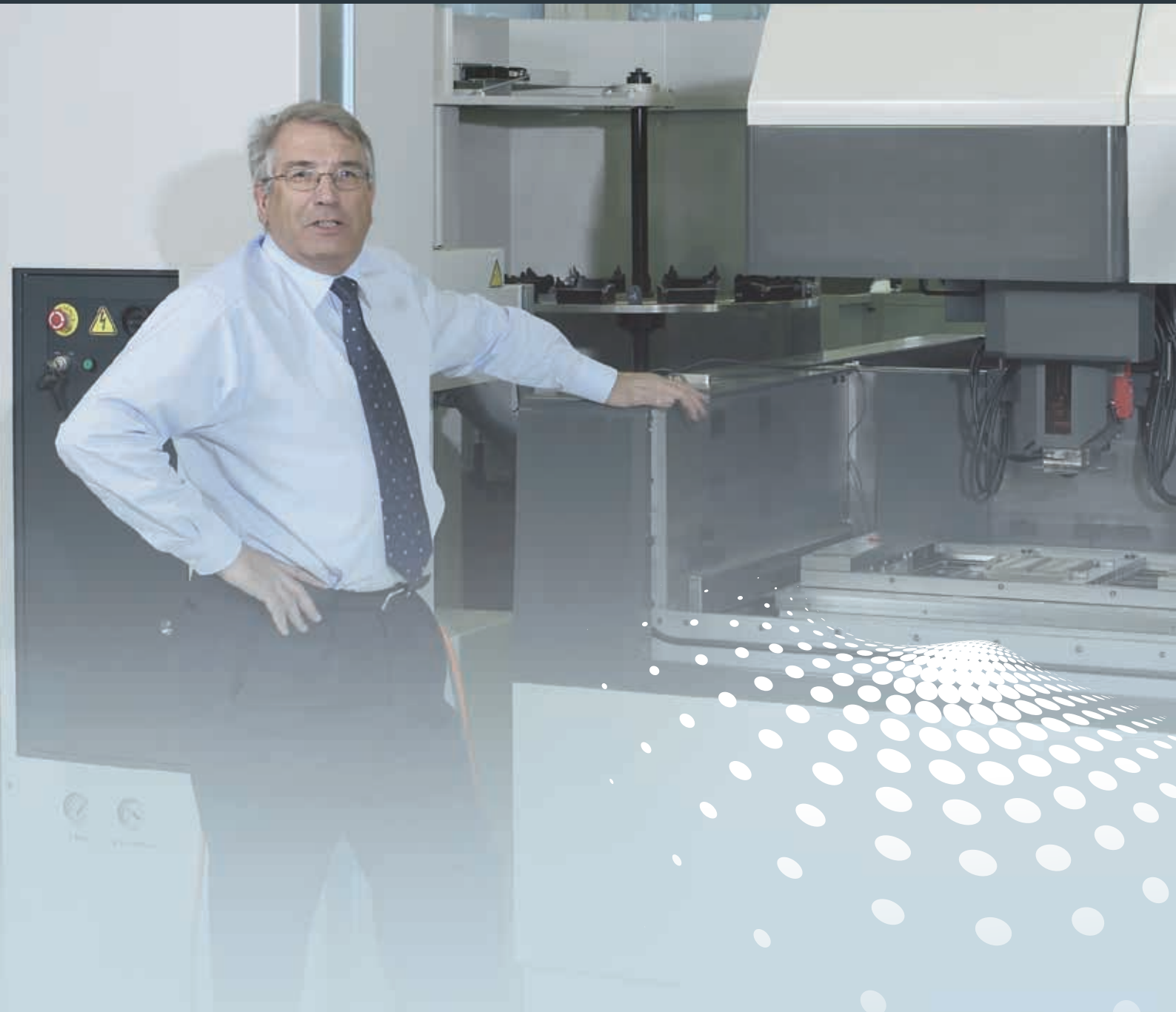

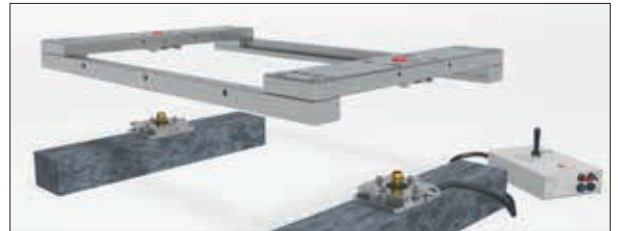

Optimal use of the machine is a key factor for competitiveness.

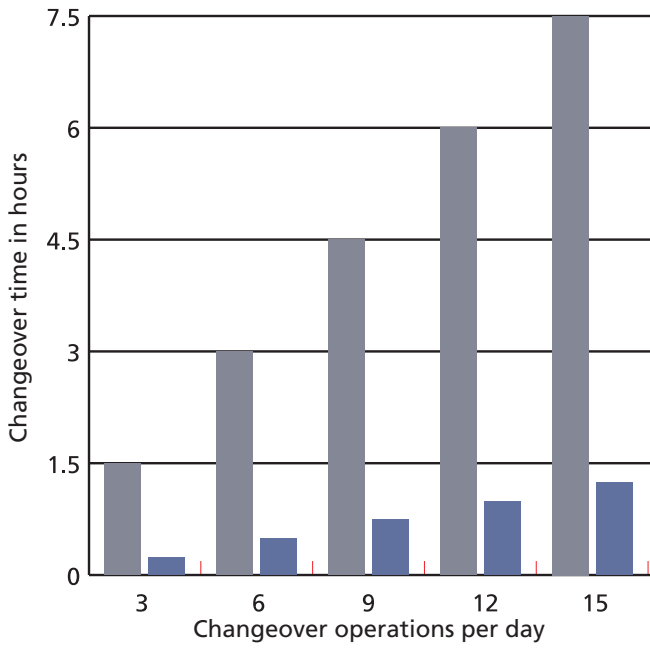
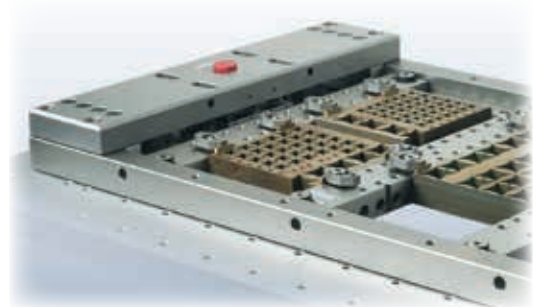

without EROWA tooling system
with EROWA tooling system

(1x changeover approx. 30 minutes)

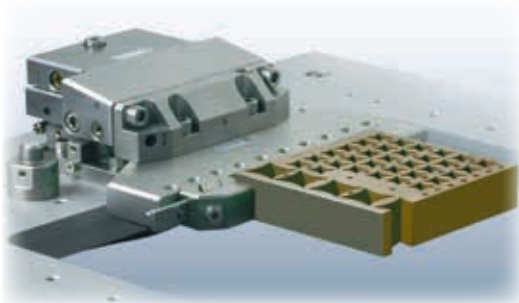

THE FACTS

- More ROI
- Less set-up time
- For each size of workpieces the matching workpiece carriers

The machine remains productive

While the next order is prepared, the machine remains productive. The set-up work is performed in an optimal environment and without time pressure. The lead time drops significantly because no set-up work is performed on the machine.

“I have plenty of time for careful and proper preparation, while the machine is running!”



Express? But of course!

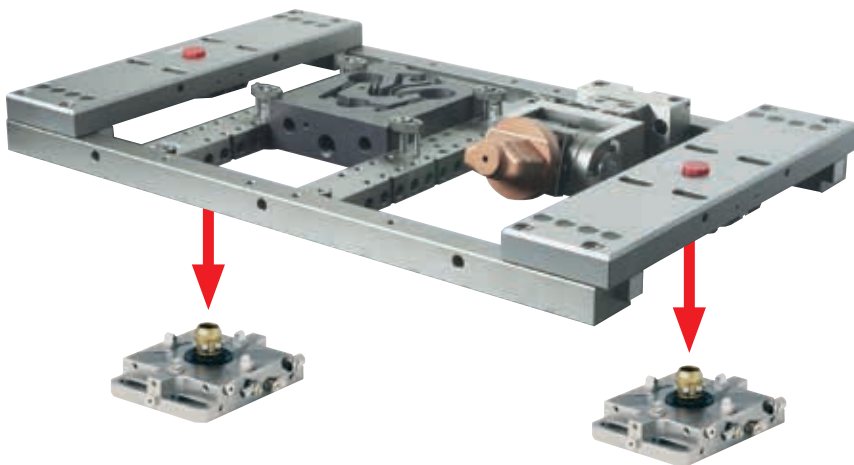
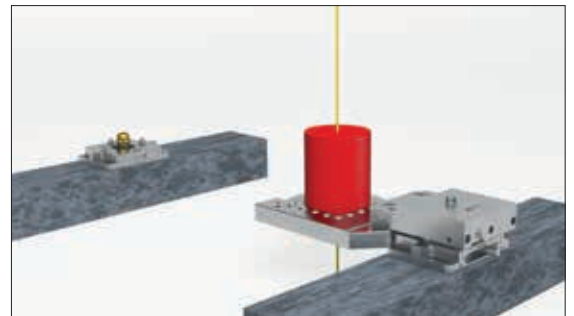
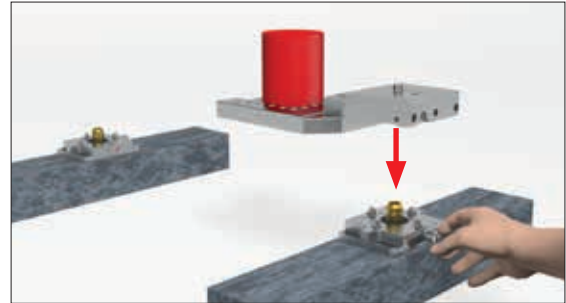
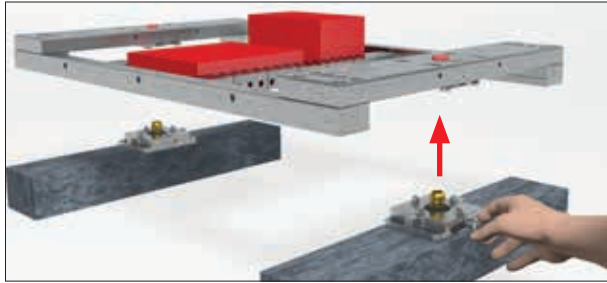
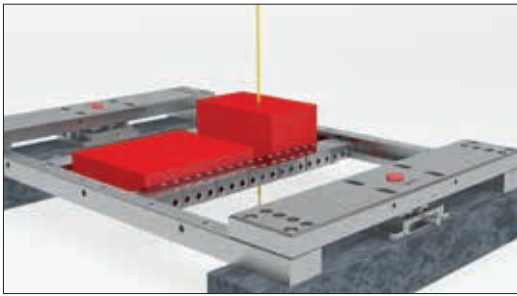

Clamping frame – for small and large workpieces.

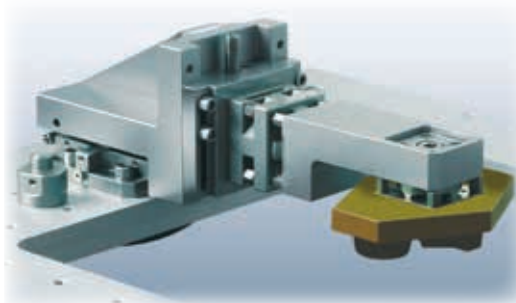
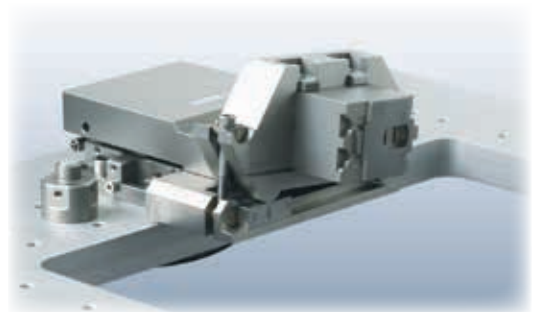

Z-Vario – each workpiece at the correct height.



THE FACTS

- Set-up during main time
- Less downtime
- Flexible mountings

Everything is possible

For every application the proper equipment.

With sophisticated combinations of vises, clamping elements and clamping beams, you can clamp all conceivable workpieces. The repeating accuracy of the EROWA Wire EDM system allows presetting outside the machine and safe automated loading. Running jobs can be interrupted for express jobs and resumed later.





Removing defective parts next to the machine. Finishing in the same mounting.

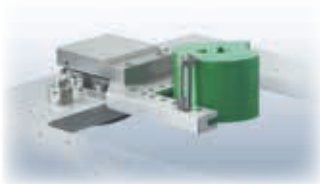

The universal vise. Leaves hardly any application needs open.



Multiple-part palletizing increases the autonomy of the machine. Makes use of the unmanned shift.

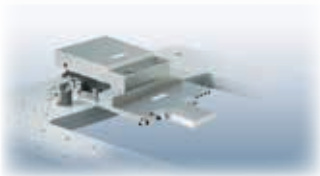

Free access for the wire guide, even if the workpiece is only a few millimeters thin.



Combination of frame and UnoSet for electrode machining.



The perfect connection to electrode manufacture.



Large workpieces are clamped individually.



Single-part palletizing in the manned shift. This is where the tricky tasks are handled.



Special mounting for cylindrical parts. Mounted to the pendulum holder, the workpiece is adjustable in three axes.

THE FACTS

- Full use of the cutting area
- For small and large workpieces.
- Z=0 for process reliability

The components

Clamping elements for the fixtures

ER-033958



ER-031952



ER-062788



ER-008231



ER-008875



ER-008873



ER-007990



ER-008220



Fixtures for the adapters

ER-031945



ER-017645



ER-019248



ER-030110



ER-018940



ER-031179



ER-018941

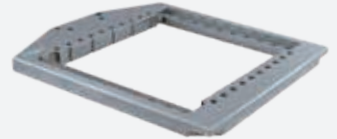

ER-025115



ER-041179



ER-035294



ER-035156

ER-033955



ER-031942



ER-039214

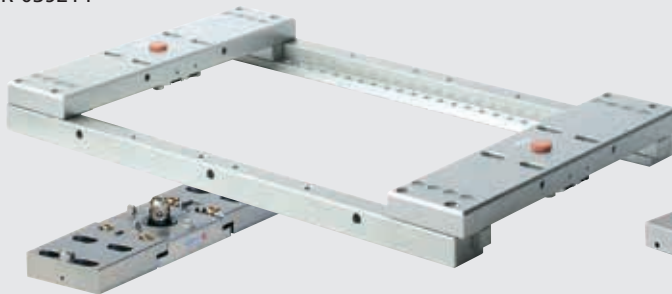

ER-037888

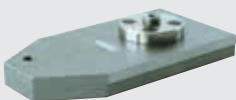

ER-055158



Interfaces for the machine table

ER-040641



ER-008221



ER-029229



ER-029228



ER-025895



ER-054922



ER-018938

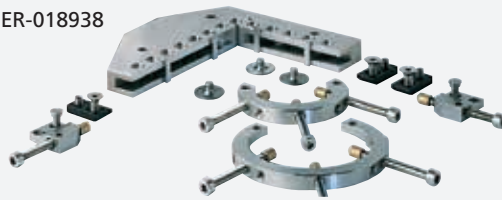

ER-038891

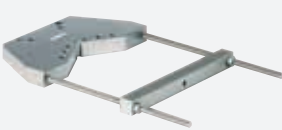

ER-018937



ER-055774



ER-051800



ER-038710



ER-033974



ER-008814



ER-008842



ER-052091



ER-007935



ER-008856



ER-016691



ER-030678

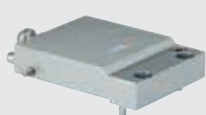

ER-039795



ER-014722



ER-014698



ER-055535



ER-030923



ER-033933



ER-012727



ER-007877



ER-038711

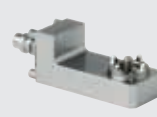

ER-028471



ER-035714



ER-035715



ER-017198



ER-007852



ER-022583



Intelligent, precise, variable and extendable

Simply remove, if the workpieces are getting too large.
The base is rebuilt and ready for use in 30 minutes.

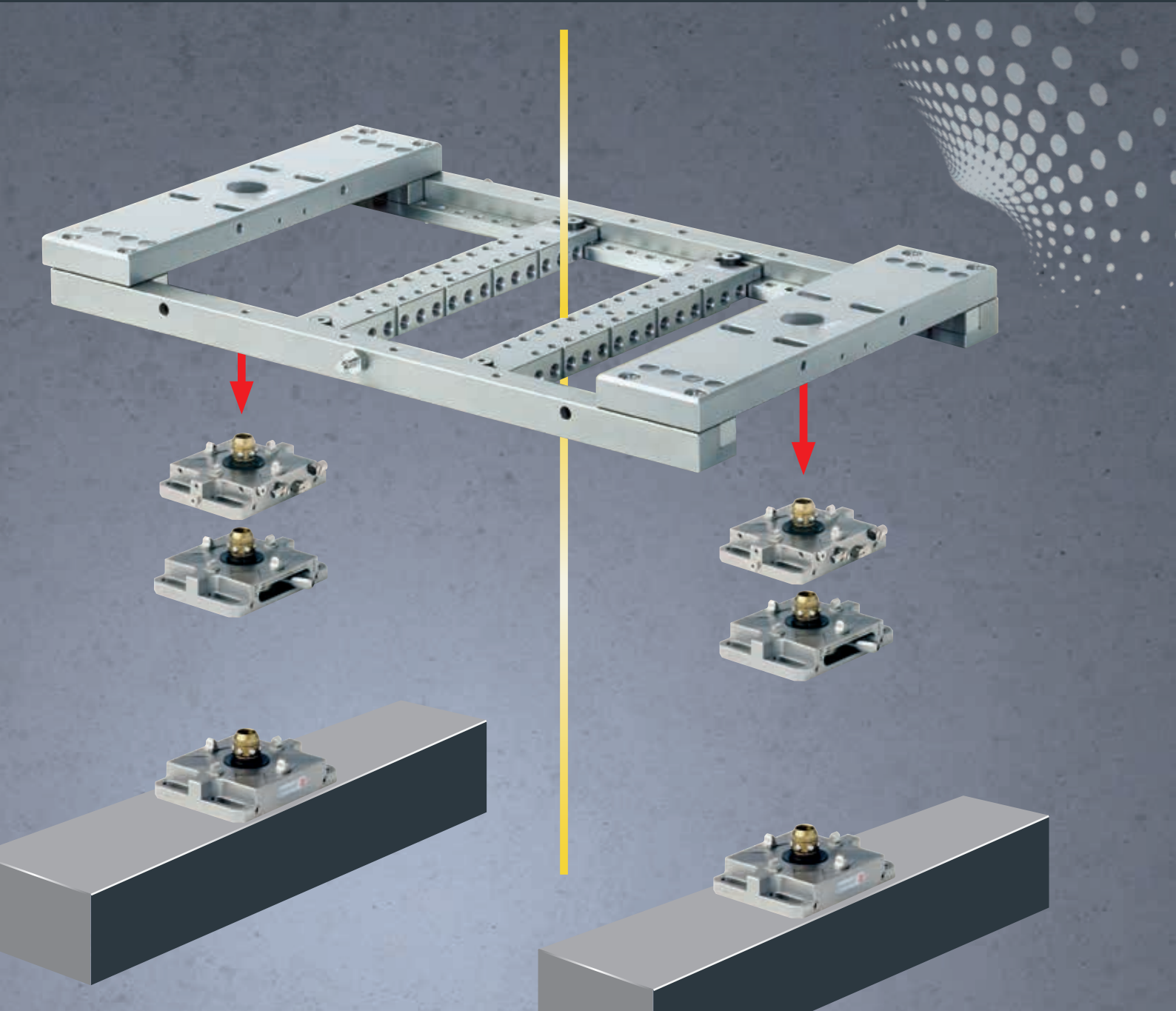

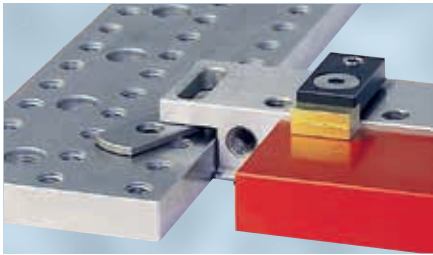

The pad raises the clamping beam with fixed support to Z=0.

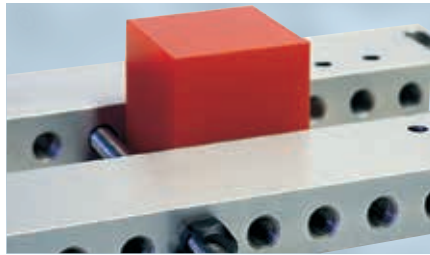

Clamping as in a vise: with the threaded rods and clamping beams.



Using removable supports where they are useful. EDM wire threading through special groove.

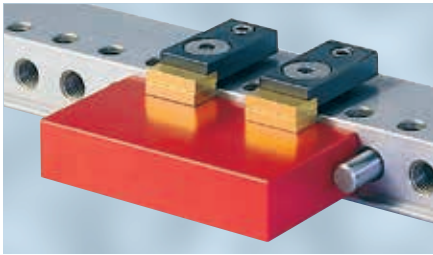

Accurately positioned with the stop pin.

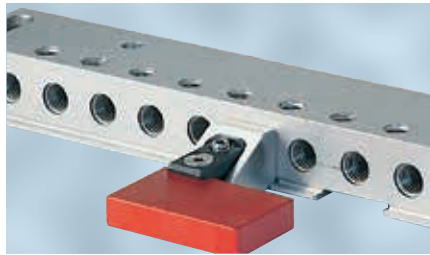

Spacer support mini for small parts.

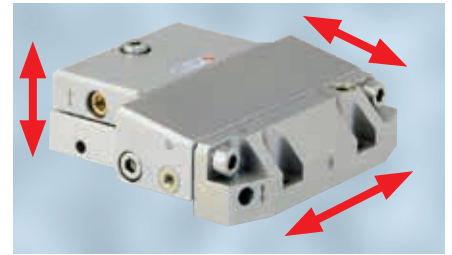

Adjustable in all axes: the pendulum holder.



For free access of the wire guide: the uni-grip vise.

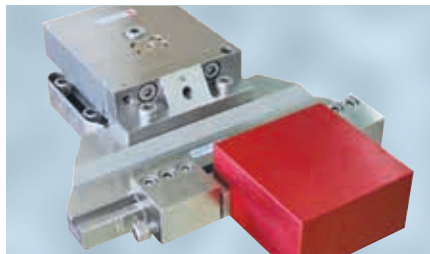

The vise with fast adjustment.

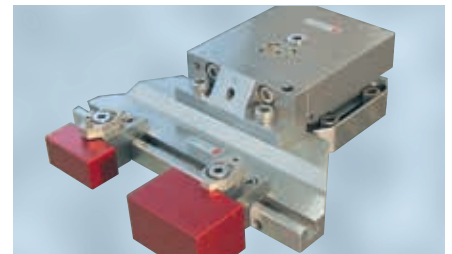

Quick conversion with modular elements.



For a special angle, continuously adjustable by 90°.

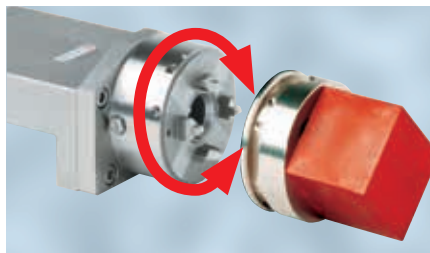

4 x 90° indexing, positioning assured in 0.002 mm.

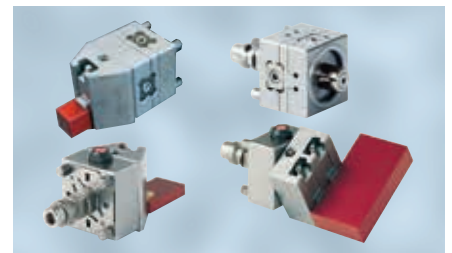

Vises with continuously rotating clamping part.

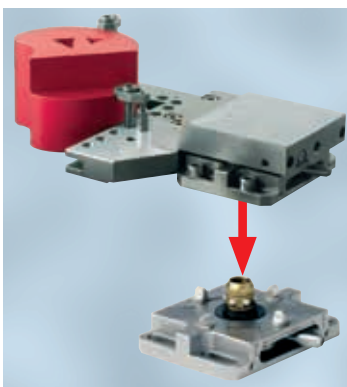

Single-part palletizing:

On the same basis as the clamping frames. Intelligent vises for clever mounting of workpieces.

THE FACTS

- Mounting for all parts
- Special solutions
- 3D alignment elements

Organizing workpieces

Presetting and measuring workpieces and electrodes are tasks that can be done more efficiently on a set-up and presetting station. Set-up during actual production gives more productive time on the machine tools. Fast in-between measurements allow the operator to manufacture with more reliability.





Determining starting borehole coordinates, establishing the spatial location of workpieces, and performing quick intermediate checks.

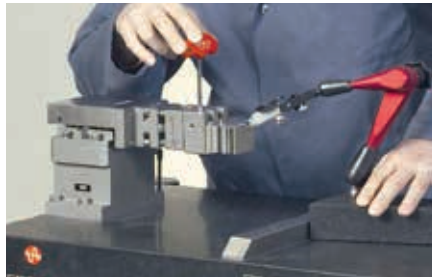

Accurate presetting of workpieces facilitates subsequent work.



Easy and fast presetting in the micron range.

Increasing productive time through automation

Automatic loading of machine tools considerably increases the proportion of productive hours. Production systems may be automated in many different ways. With a large selection of EROWA handling systems, we can meet your requirements with regard to transfer weight, magazine capacity and control interface.



We have the right automation solution also for you! EROWA provides a wide selection of various handling facilities. We'll be happy to advise you!



The workpiece carrier is positioned precisely on the chuck.

Efficiency improvements

In many companies, the production facilities are not optimally used. Quality and feasibility of new products were in the foreground until recently. These expenses were also paid for until a few years ago. Increases in capacity were offset by investments in new machines.



Gaining time and saving money with EROWA

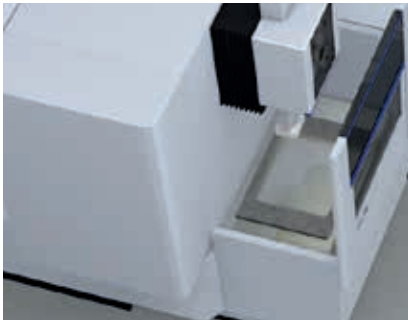

WEDM machine without EROWA datum point tooling system

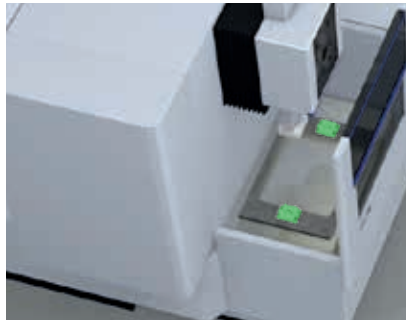

WEDM machine with EROWA datum point tooling system

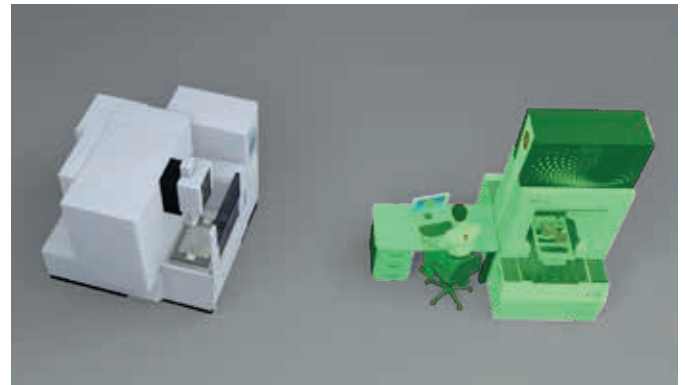

... and EROWA PreSet ...

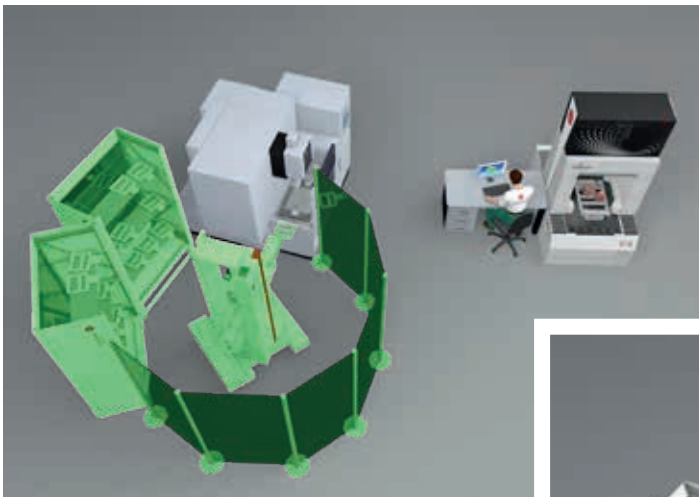

... and EROWA robot ...

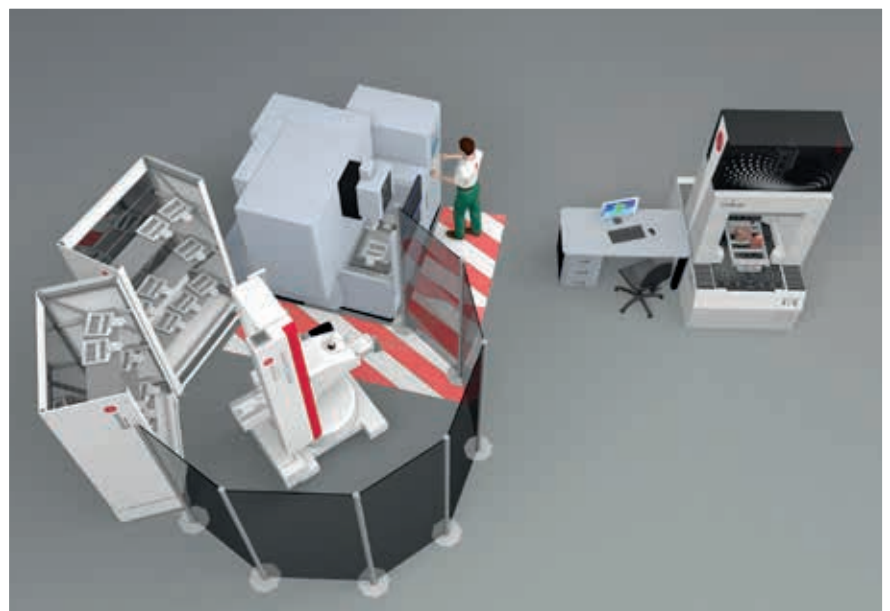

... and EROWA process control system.

THE FACTS

- Making the best use of time
- Simplifying mounting operations
- Increasing productivity

The next step

Important things need to be planned. And your next step is certainly among the important things. For it is your start into a new, efficient era. We are pleased to be with you on the way. As consultants, in practice. For you to know at all times what you're engaging in. The next EROWA branch office is not far – **take the step.**



USA

EROWA Technology, Inc.
North American Headquarters
2535 South Clearbrook Drive
Arlington Heights, IL 60005
USA
Tel. 847 290 0295
Fax 847 290 0298
e-mail: info@erowa.com
www.erowa.com

Italy

EROWA Tecnologie S.r.l.
Sede Legale e Amministrativa:
Via Alfieri Maserati 48
IT-10095 Grugliasco (TO)
Italy
Tel. 011 9664873
Fax 011 9664875
info@erowa.it
www.erowa.com

Unità di Treviso:
Via Leonardo Da Vinci 8
IT-31020 Villorba (TV)
Italy
Tel. 0422 1627132

Singapore

EROWA South East Asia Pte. Ltd.
56 Kallang Pudding Road
#06-02, HH@Kallang
Singapore 349328
Singapore
Tel. 65 6547 4339
Fax 65 6547 4249
sales.singapore@erowa.com
www.erowa.com

Japan

EROWA Nippon Ltd.
Sibadaimon Sasano Bldg.
2-6-4, Sibadaimon, Minato-ku
105-0012 Tokyo
Japan
Tel. 03 3437 0331
Fax 03 3437 0353
info@erowa.co.jp
www.erowa.com

Switzerland

EROWA AG
Knutwilerstrasse 3
CH-6233 Büron
Switzerland
Tel. 041 935 11 11
Fax 041 935 12 13
info@erowa.com
www.erowa.com

France

EROWA Distribution France Sàrl
PAE Les Glaisins
12, rue du Bulloz
FR-74940 Annecy-le-Vieux
France
Tel. 4 50 64 03 96
Fax 4 50 64 03 49
erowa.france@erowa.com
www.erowa.com

Spain

EROWA Technology Ibérica S.L.
c/ Avda. Cornellà, 142 7ª 3ª ext.
E-08950 Esplugues de Llobregat - Barcelona
Spain
Tel. 093 265 51 77
Fax 093 244 03 14
erowa.iberica.info@erowa.com
www.erowa.com

China

EROWA Technology (Shanghai) Co., Ltd.
G/F, No. 24 Factory Building House
69 Gui Qing Road (Caohejing Hi-tech Park)
Shanghai 200233, PRC
China
Tel. 021 6485 5028
Fax 021 6485 0119
info@erowa.cn
www.erowa.com

Germany

EROWA System Technologien GmbH
Gewerbegebiet Schwadernmühle
Roßendorfer Straße 1
DE-90556 Cadolzburg/Nbg
Germany
Tel. 09103 7900-0
Fax 09103 7900-10
info@erowa.de
www.erowa.de

Scandinavia

EROWA Technology Scandinavia A/S
Fasanvej 2
DK-5863 Ferritslev Fyn
Denmark
Tel. 65 98 26 00
Fax 65 98 26 06
info.scandinavia@erowa.com
www.erowa.com

Eastern Europe

EROWA Technology Sp. z o.o.
Eastern Europe
ul. Spółdzielcza 37-39
55-080 Kąty Wrocławskie
Poland
Tel. 71 363 5650
Fax 71 363 4970
info@erowa.com.pl
www.erowa.com

India

EROWA Technology (India) Private Limited
No: 6-3-1191/6, Brij Tarang Building
Unit No-3F, 3rd Floor, Greenlands, Begumpet,
Hyderabad 500016 (Telangana)
India
Tel. 040 4013 3639
Fax 040 4013 3630
sales.india@erowa.com
www.erowa.com